

Hydramotion

viscosity



XL3

mini viscometer

Quick-start guide

Guarantee

Hydramotion Ltd will repair an XL3 transducer free of charge within 24 months of the date of purchase if satisfied that:

- (i) the fault is the result of defective materials and/or workmanship, and
- (ii) the instrument is returned to Hydramotion Ltd carriage prepaid and undamaged in transit.

This Guarantee shall not apply to any fault resulting from:

- (i) negligence or lack of proper care by the owner or user,
- (ii) failure to follow (a) the instructions and recommendations given in this User Manual or (b) any additional instructions from Hydramotion regarding instrument installation or operation, or
- (iii) normal wear and tear on the instrument.

Hydramotion Ltd shall in no case be liable for any loss of output, revenue or any other losses or costs, consequential or otherwise, howsoever incurred.

Note: This Guarantee is made void by any attempt to alter, take apart, or tamper with any part of the product without express written permission from Hydramotion Ltd.

Hydramotion

1 York Road Business Park, Malton, York, England YO17 6YA
Tel: +44 (0) 1653 600294 • sales@hydramotion.com
www.hydramotion.com



Designed and manufactured entirely in the United Kingdom

1

Package contents

- Do not attempt to unscrew or disassemble the instrument. There are no user-servicable parts. Doing so will void the guarantee.
- Retain the packaging, it might be needed to return the instrument for any periodic calibration checking or servicing.

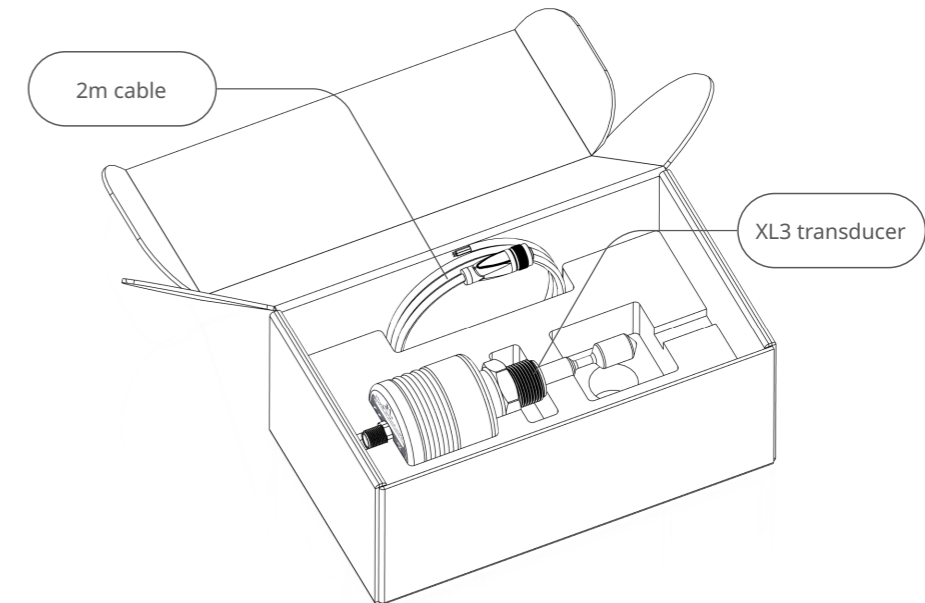

For additional information, please refer to the main user manual. Go to <https://hydramotion.click/xl3> or scan the QR code to the right to be taken to our online support portal.



2

Product dimensions

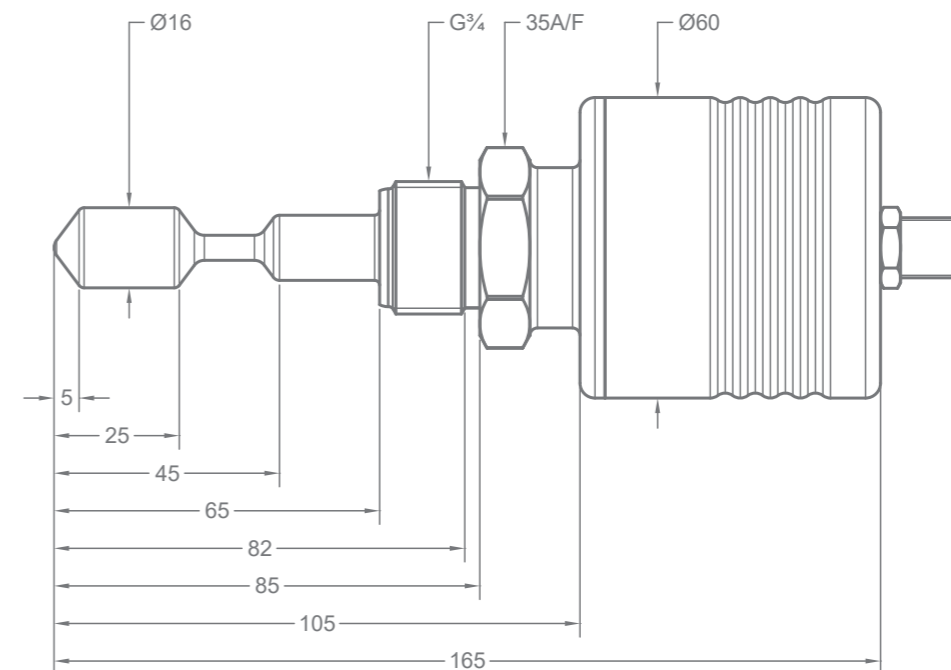

All dimensions in mm

3 Handling & specification

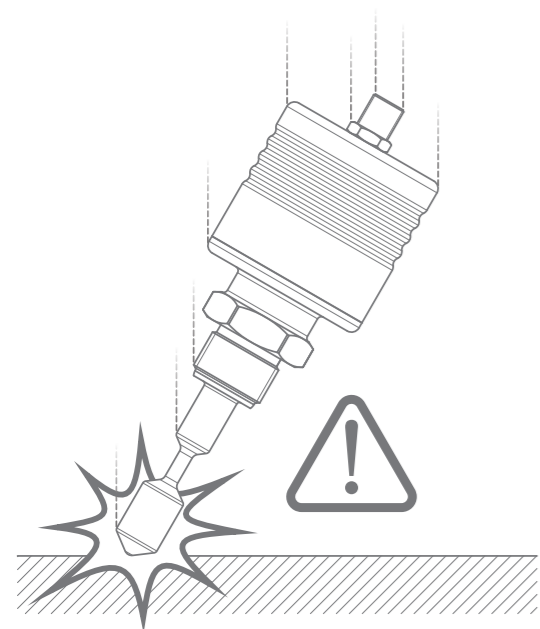

Any damage to the sensing shaft could affect reliability of readings.

- Viscosity range 0 - 5,000 cP
- Measurement time 1 second
- Accuracy 1% of reading and ± 0.1 cP
- Repeatability 0.3% of reading and ± 0.05 cP
- Analogue outputs 1 x 4-20mA configurable, representing either dynamic viscosity, kinematic viscosity, temperature corrected viscosity, or temperature
- Digital outputs RS485 Modbus® data link
- Power requirements 12 - 24V DC @ 60 mA
- Integral thermometer integrated temperature measurement
- Process Temperature range -30 to +100 °C
- Maximum instrument pressure 50 bar
- Process connection pipe thread ISO 228 - G¾ (¾" BSPP)
- Cable length up to 1.2km
- Connector type 5 way M12 male connector A-coding
- Construction all-welded, crevice-free
- Materials head: acetal homopolymer
sensor: SS316 (EN 1.4401)
- Surface finish N6 0.8 µm Ra
- Weight 750 g
- Ingress protection IP67
- Software V Link configuration utility

4 Physical installation

- The XL3 is a Safe-Area only instrument.
- Mountable in any orientation, on a process fitting compatible with the process connection.
- Some of the preferred mounting options are shown below.
- Can be used with virtually any size pipe or tank.
- Thread should be sealed with a bonded seal, Dowty type, or O-Ring with back-up washer (not provided).

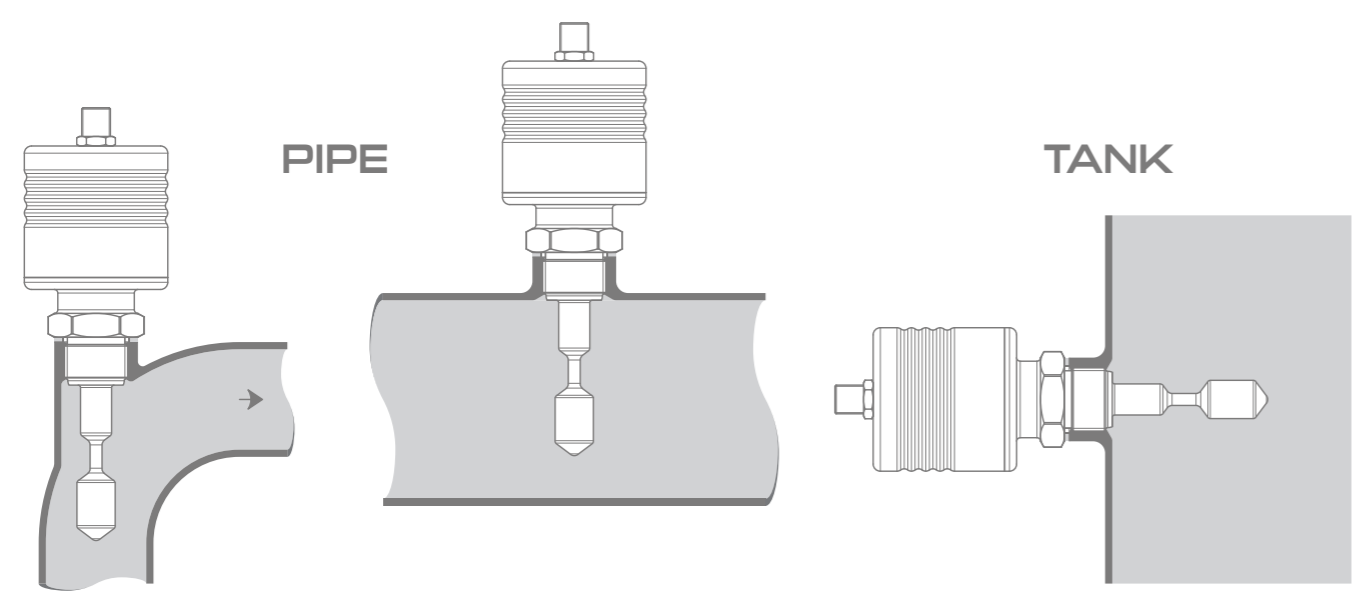

5 Electrical hookup

- All connections are made via the 5 way M12 A-coded connector.
- The supplied 2m cable is unshielded. For extended runs or installations in high-interference environments, a shielded cable is recommended to ensure signal integrity.
- RS-485 and 4-20 mA may be used independently or in combination. Dashed lines indicate optional connections.

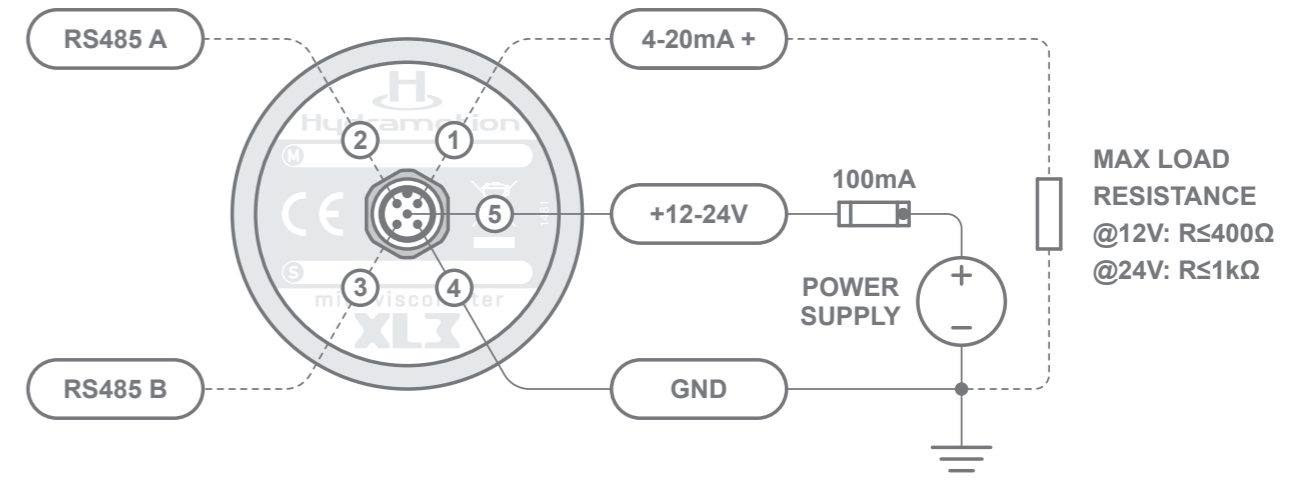

6 Modbus® ASCII/RTU

Input registers (FC04) Serial settings: 9600 baud, even parity, 8 data bits, 1 stop bit

Description	UINT16 Address	Scaling factor	FLOAT32* Address
Averaged live viscosity (cP)	0x0000	0 to 5000†	0x2000 - 0x2001
Average temp corrected viscosity (cP)	0x0001	0 to 5000†	0x2002 - 0x2003
Density (g/cm³)	0x000B	0 to 20	0x2016 - 0x2017
Temperature (°C)	0x0013	-50 to 500	0x2026 - 0x2027

Holding registers (FC03 / FC16) - Also configurable with our V Link utility. Download available on the support portal.

Description	UINT16 Address	Scaling factor	FLOAT32* Address
Analogue out low scale	0x0010	No scaling	0x2020 - 0x2021
Analogue out high scale	0x0011	No scaling	0x2022 - 0x2023
Dynamic viscosity scaling span	0x0013	No scaling	0x2026 - 0x2027
Dynamic viscosity scaling offset	0x0014	No scaling	0x2028 - 0x2029
Tolerance band	0x0015	No scaling	0x202A - 0x202B
Average filter	0x0016	No scaling	0x202C - 0x202D
Density (g/cm³)	0x0018	0 to 20	0x2030 - 0x2031
Reference temperature	0x0017	-50 to 500	0x202E - 0x202F
Temperature correction factor	0x0029	No scaling	0x2052 - 0x2053

For a complete list of register values, refer to the main user manual.

* FLOAT32 values use IEEE 754 format, big-endian byte order, and are transmitted with the high word first (register n = high word, n+1 = low word). Do not use FC06 for writing to holding registers.
† Default values, user-configurable and are bound to 4-20mA low and high range settings.